

HANTEMP Controls

Bulletin GV116e

SGV Stainless Steel Gauge & Purge Valve

Made in
U.S.A

iiar
International Institute of
Ammonia Refrigeration

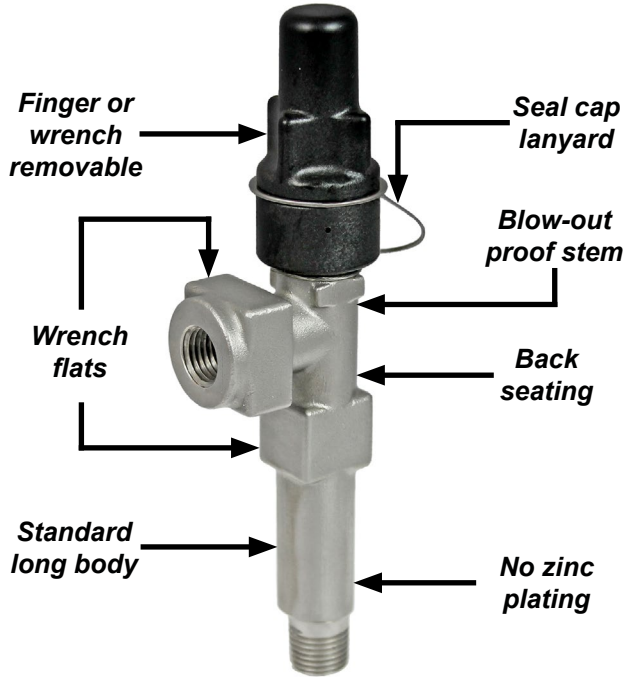

SGV Gauge Valve

DESCRIPTION

The SGV **Stainless Steel Gauge Valve** from HANTEMP Controls is designed to meet industrial refrigeration and other application requirements. The valve's stainless steel construction provides superior corrosion resistance, whereas existing gauge valves of ordinary steel are subject to rusting and low-temperature embrittlement. The SGV is designed for simple handling and maintenance, with wrench flats on the valve body and a seal cap removable via a wrench or fingers. The standard SGV, with long lasting stainless-to-stainless seating to guarantee tightness, has been approved for compatibility with all common refrigerants including ammonia, CO₂, and secondary refrigerants.

APPLICATIONS

The SGV Gauge Valve is generally used to isolate gauges and other sensors for industrial refrigeration systems. It can also be used for pumpout or venting of components. However, the SGV is too small for most oil drain applications.

STAINLESS STEEL GAUGE VALVE FOR REFRIGERATION

- Ideal for isolation of pressure gauges for system lifetime
- Suitable for valve venting & pump out
- 1/4" MPT (bottom) and 1/4" FPT (side)
- Available as standard extended neck body (SGV) or compact body (SGVC)
- Model SGVX for Transcritical CO₂ (contact factory)
- Seal cap lanyard standard

MATERIALS & SPECIFICATIONS

Body: 300 Series Stainless Steel

Stem: 300 Series Stainless Steel

Seal Cap: Proprietary Polycarbonate

Rotary Stem Seals: Dual Teflon & Synthetic

Spirolox[®] Retaining Ring: 300 Series SS

Safe Operating Pressure: 800 psig

Approved Operating Temperature:
-75°F to +240°F

Approved Refrigerants Include:

R717 (NH₃), R744 (CO₂), Halocarbons, Glycols, Brines, Water, and Aqueous Ammonia

SGVC with 3 1/2" Gauge

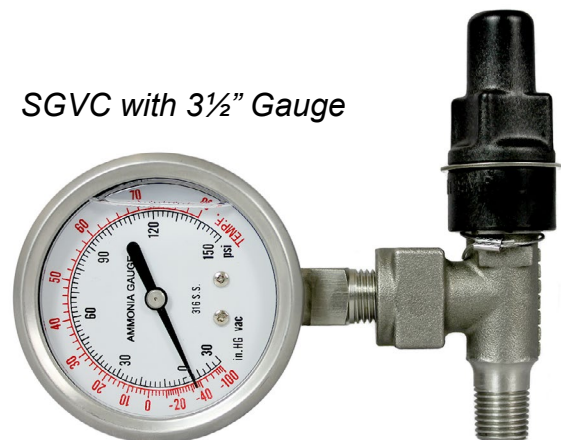

Gauge Valve Installation Dimensions

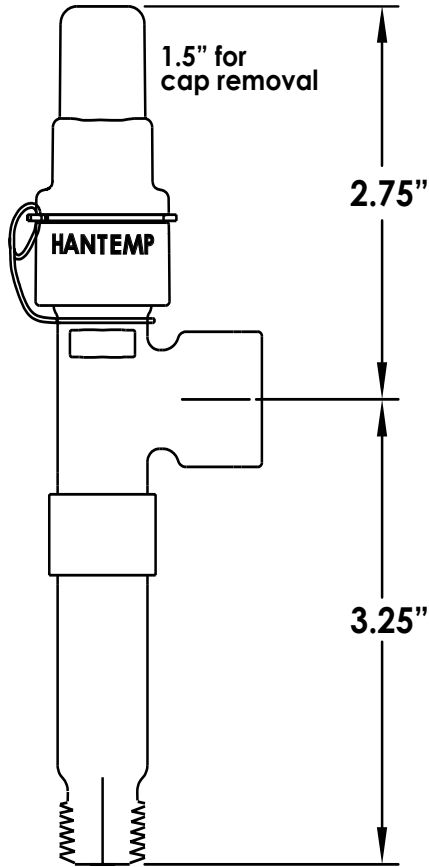

SGV - Standard Extended Neck

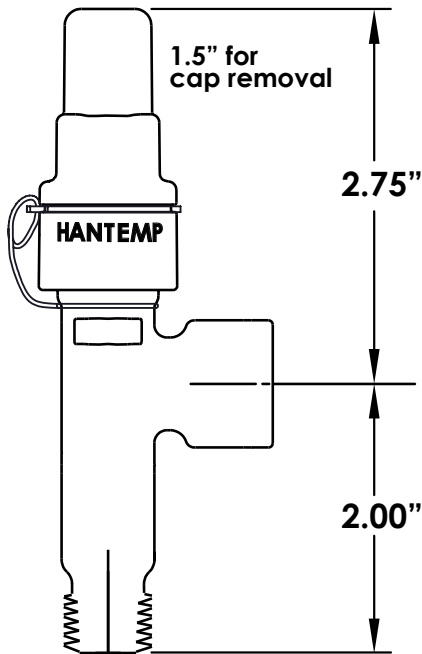

SGVC - Compact Body

HANTEMP Controls reserves the right to alter product specifications, materials, and pricing without notice.

Stainless Steel Gauge Valve

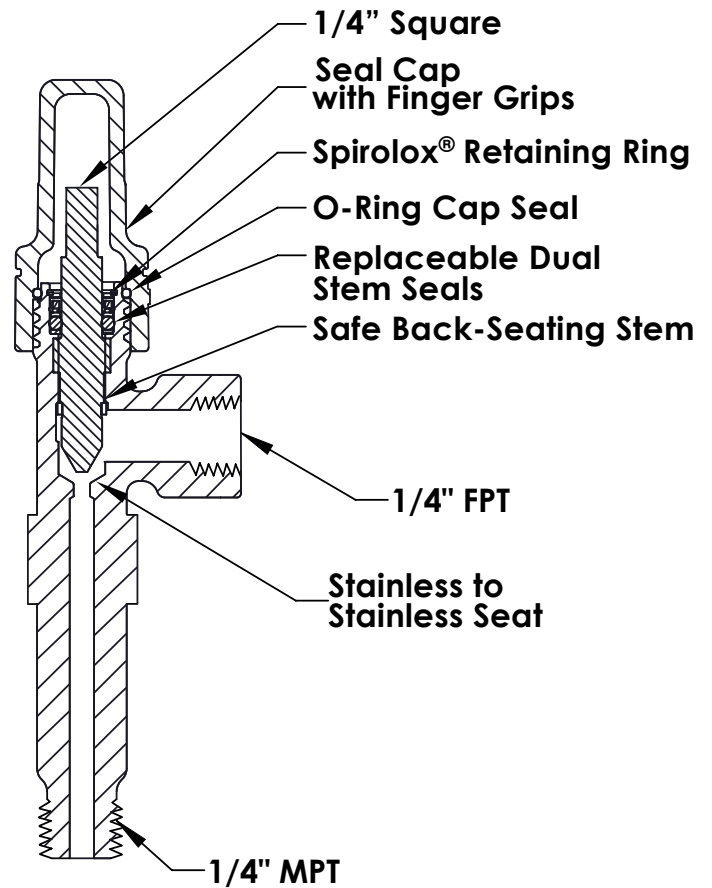

SAFETY WARNING

The valve should be installed, maintained, and serviced only by an experienced refrigeration professional. This includes reading and understanding pertinent product safety bulletins and installation instructions. Before servicing, the valve should be isolated from the system and all refrigerant evacuated from the piping section.

WARRANTY

All HANTEMP Controls products are warranted against defects in workmanship and materials for a period of one year from date of shipment from the factory. This warranty period is applicable only when products are properly installed, operated, and serviced as specifically stated in HANTEMP Controls product bulletins unless otherwise approved in writing by HANTEMP Controls.

HANTEMP Controls

33 Chestnut Avenue Westmont, IL, USA
(630) 537-1049 • www.hantempcontrols.com