

# HANTEMP Controls

Bulletin FS0217d

SSLL “SEE-SWITCH”®

Liquid Level Float Switch

Made in  
U.S.A.

**iiar**  
International Institute of  
Ammonia Refrigeration



*The Most Reliable Float Switch*

## DESCRIPTION

The HANTEMP “SEE-SWITCH”® **Stainless Steel Float Switch** is an improvement over conventional steel float switches. The stainless steel tank resists corrosion caused by condensation that occurs when cold liquid is being measured. In addition, the SSLL has lighter but stronger than steel float switch tanks. The LS switch housing features a neon yellow indicator wand that provides the operator a visual indication of the switch position. The switch arm Neodymium magnet is non ceramic solid metal.

## APPLICATIONS

The SSLL “SEE-SWITCH”® Float Switch is used to open and close solenoid valves, electrical relays, pilot lights, and magnetic starters. It is also a device to actuate alarms and lights when an abnormally high or low liquid level occurs in the connected vessel.

## STAINLESS STEEL REFRIGERATION FLOAT SWITCH

- The SSLL is interchangeable with competitors' tanks
- Half the weight of ordinary steel
- Suitable for ammonia, halocarbons, and other approved refrigerants
- IP65 Electrical Enclosure
- DIN Connector & 1/2" Conduit
- Variable level model is also available (SSLLA)

## MATERIALS & SPECIFICATIONS

**Operating Pressure:** 800 PSIG (55 Bar)

**Operating Fluid Temperature:**  
-100°F to +150° F (-73°C to +65° C)

**Ambient Temperature:**  
-50°F to +120° F (-45°C to +48° C)

**Approved Refrigerants Include:**  
NH<sub>3</sub>, CO<sub>2</sub>, Glycols, Brines, Water, Light Oils, Hydraulic Fluids, and other liquids as approved.

**LT Tank Material:** Stainless Steel; with 3/4" FPT/1" Butt Weld side and bottom connections. Stainless steel float ball & trim.

**LS Switch Assembly:** Clear polycarbonate, UV resistant, transparent, sealed housing, featuring a very reliable non-electronic Honeywell Micro-Switch® SPDT 15 Amp 24/115/230 VAC capacity and “SEE-SWITCH”® position indicator wand. A DIN quick disconnect connector with 36" wire leads is standard; 1/2" FPT conduit connection is inherent.

# LIQUID LEVEL FLOAT SWITCH

## Cross Section & Operation

When the Float Tank is empty of liquid, the Float Ball rests on the lower Buffer Spring. In this position, the magnetic stainless steel Attractor is down from the magnetic field of the Neodymium Magnet and the Microswitch is in its normal position. This would be normally open (NO) black on one switch terminal and normally closed (NC) red on the other terminal: the common terminal (COM) is gray and never changes.

As liquid fills the tank via the bottom connection (due to a rise in system liquid level), the Float Ball will rise, the Attractor moves upward into the magnetic field and the switch arm is pulled to actuate the switch. In this case the switch (NO) becomes closed; in this position the switch actuating level is Switch-In. At levels above the switch actuating level, there is no further change in switch operation, even if the liquid level rises well above this point.

As liquid level drops (lowers) from this position, the Float Ball will pull the Attractor downward until, at a dropping level 2 inches below the actuation level,

the magnet drops away from the Attractor and the switch is Deactuated (Switch-Off). The normally open contact (NO) opens. Further lowering of liquid level has no additional effect on the Float Switch. This 2 inch differential has proven to be best for most applications to give adequate precision control of level without "short cycling" of solenoid valves or pumps.

For ammonia liquid at +20°F, or an equal specific gravity liquid, the switch actuating point occurs when the liquid rises to 1/2 inch below the centerline of the side pipe connection on the tank. These actuating points are diagrammed in the bulletin and on the tank nameplate. The drop out point for switch De-actuation on falling liquid level is always down 2.0 inches below this point regardless of refrigerant or liquid density.

As shown on the liquid level diagram (page 3) the Actuating point (pull-in) for other more dense fluids, such as R134a, could be as much as 1 1/2 inches lower than ammonia. The De-actuating switch level remains 2.0 inches below the particular fluid actuating level.

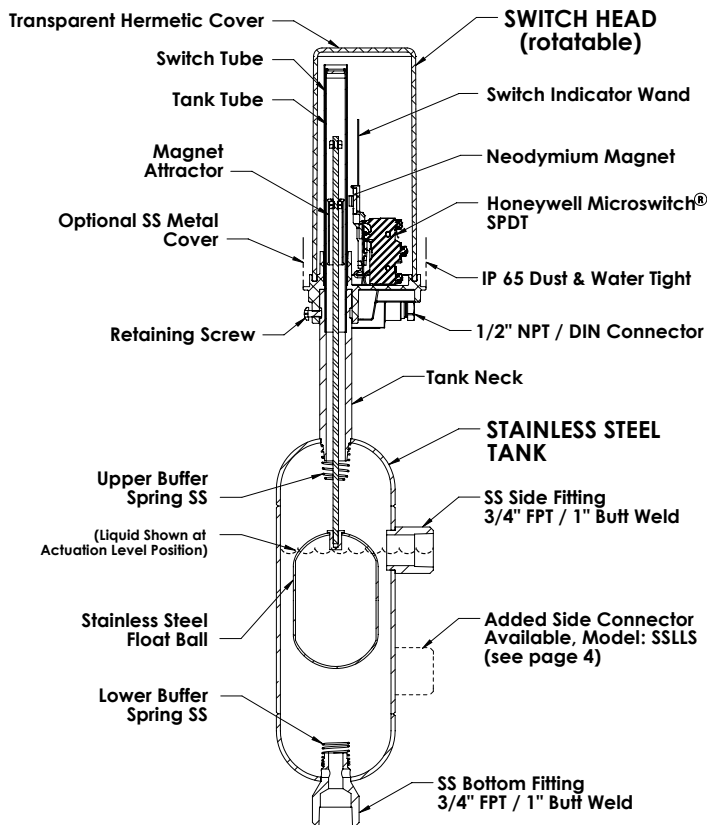

Cross Sectional Diagram: SSSL TANK & SWITCH HEAD

## COMPETITIVE FLOAT SWITCHES

### Dimensional Comparison

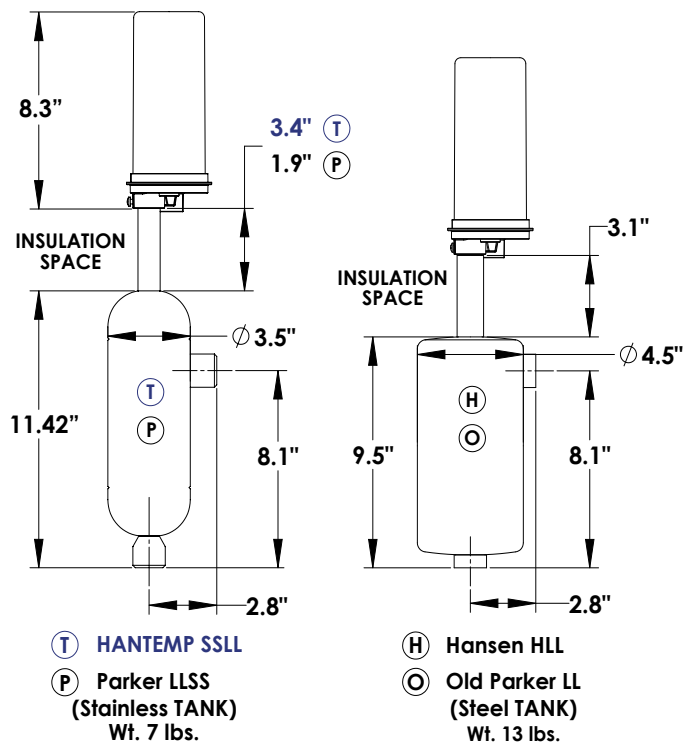

**(T)** HANTEMP SSSL  
**(P)** Parker LLSS  
 (Stainless TANK)  
 Wt. 7 lbs.

**(H)** Hansen HLL  
**(O)** Old Parker LL  
 (Steel TANK)  
 Wt. 13 lbs.

\*HANTEMP SSSLA (see page 4) -  
 Tank Length: 19.4"  
 Overall Length: 38.3"

# INSTALLATION INSTRUCTIONS

Remove the transparent Switch Head from the carton, and keep it separate and protected during piping activity. When ready for wiring, after Tank installation, examine this "circled" wiring diagram as also on the top of the Switch Head and proceed with wiring. The float switch tank installation must permit 24 inches (60 cm) of clearance from the top of the tank to allow the switch assembly to be installed or replaced. Prior to activation, examine switch assembly wiring. Manual actuation of the switch may be done by use of a screwdriver blade inserted into the Head tube to actuate the magnet and switch lever, simulating the presence of liquid up into the tank. The wire entry into the Switch Head is via a DIN 3 pole connector plus ground as diagrammed at right. Wiring to control circuit is via a 4 wire cord or a 1/2" NPT metal conduit pipe with insulated wires connected to an electrical box directly or via a flexible metal conduit. The tank, within its height limitation, has the same liquid level as its connected vessel or column and can thus be used to control such level via switching solenoid valves, or pumps, or alarms, or other devices.

## DIN Connector Wiring

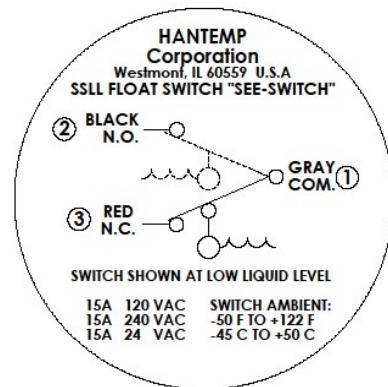
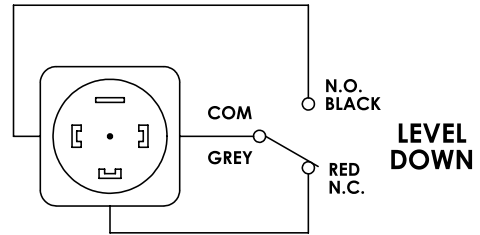
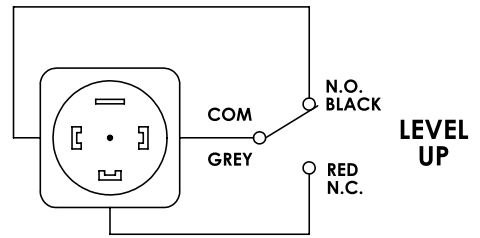

SWITCH HEAD Label

## LIQUID LEVEL ACTUATION LEVELS FOR VARIOUS LIQUIDS

Specific gravity shown at switch-in point, deactuation is 2" lower than switch-in point

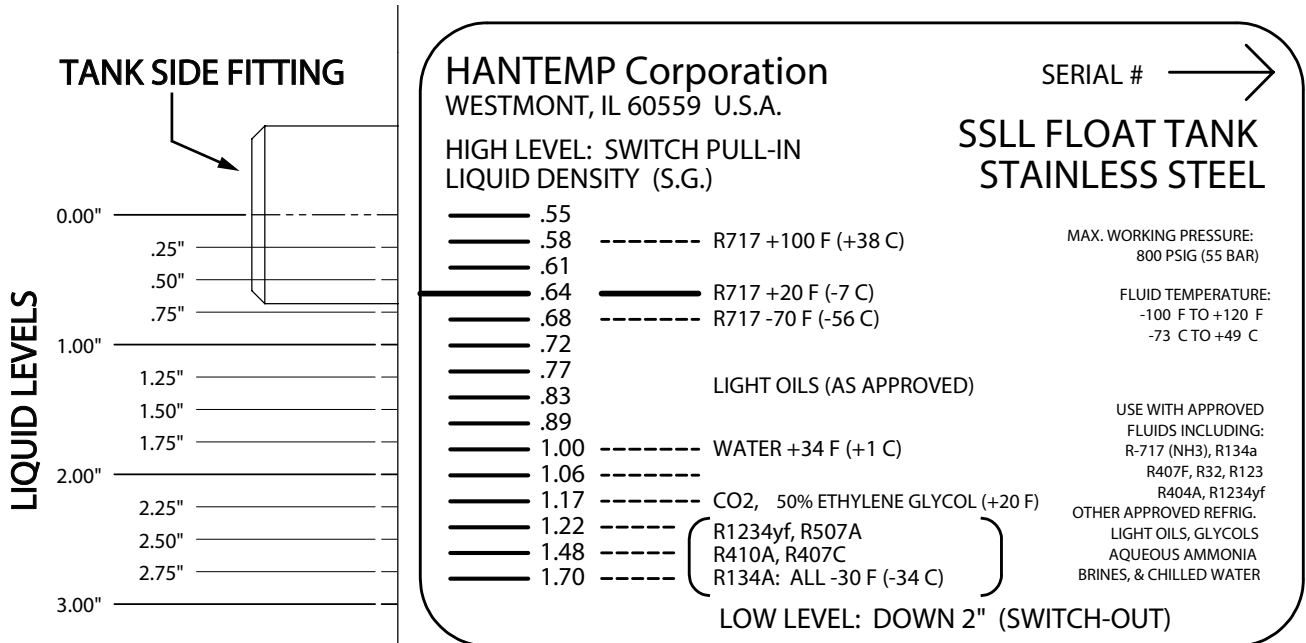

Float Switch Tank Label

# TYPICAL FLOAT SWITCH APPLICATIONS

Idea schematics; not detailed for construction.

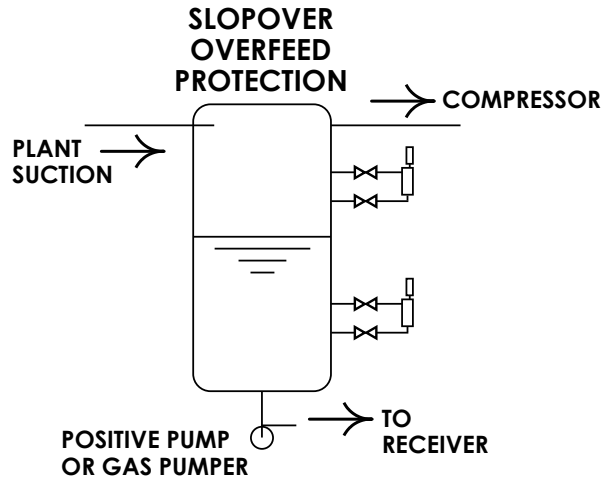
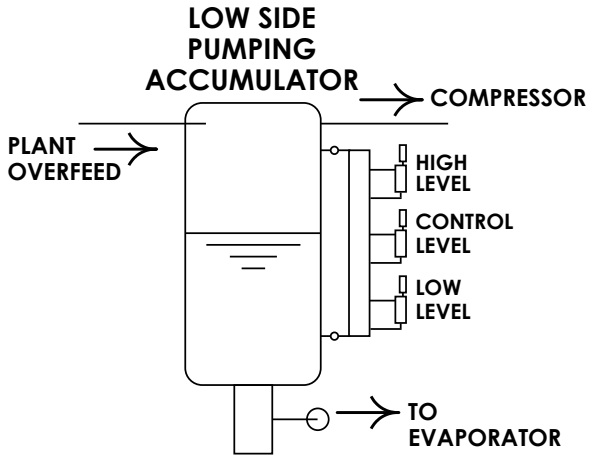

## ADDITIONAL FLOAT SWITCH MODELS AVAILABLE

### SSLLS - Dual Side Connector Model

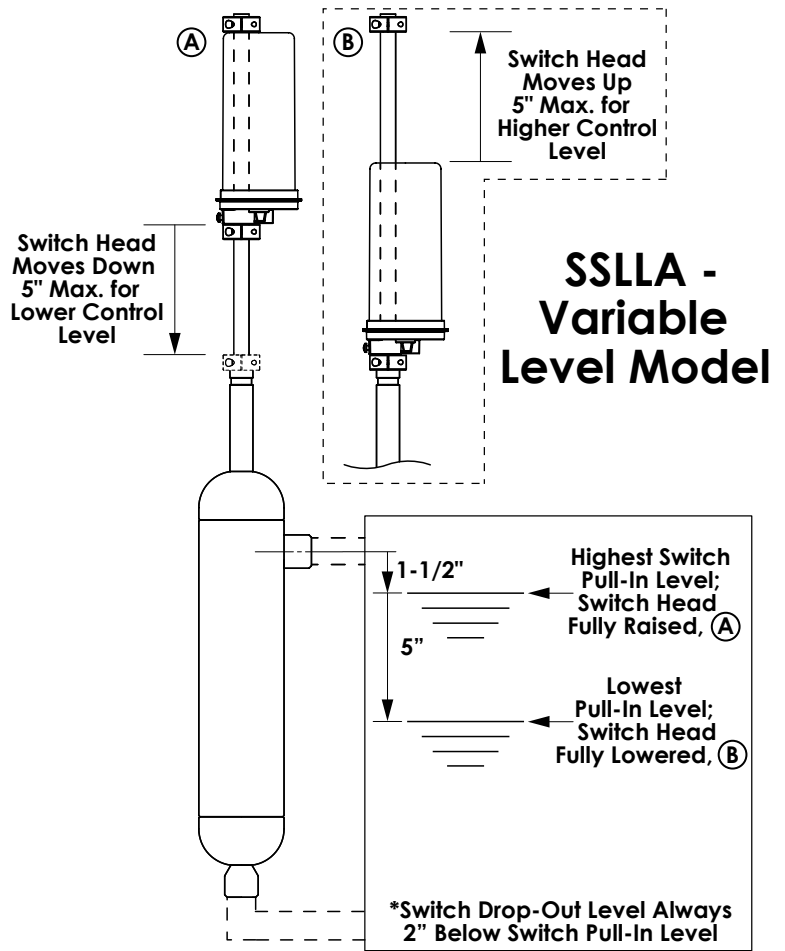
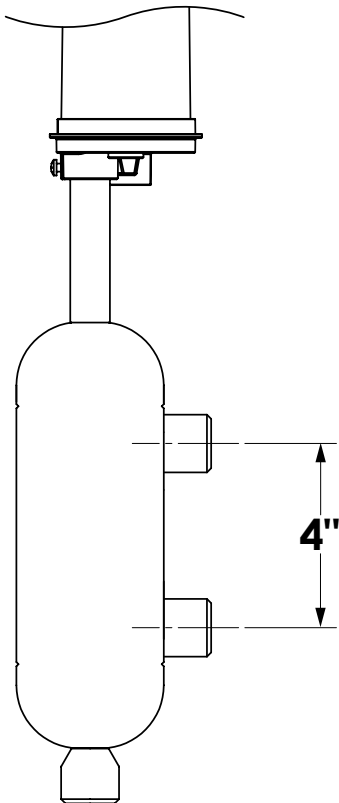

"SEE-SWITCH" <sup>®</sup> Switch Head (Only) Replacement Capability	
HANTEMP SSLL	Exact Replacement
Parker LLSS	Suitable Replacement
Hansen Technologies HLL, HLLS & Parker (old model) LL, LLS	Suitable Replacement with 7/16" Spacer (.44" higher level) Included

## HANTEMP Controls

33 Chestnut Avenue, Westmont, IL, USA

(630) 537-1049

[www.hantempcontrols.com](http://www.hantempcontrols.com)

HANTEMP Controls reserves the right to alter product specifications, materials, and pricing without notice.